



# Year 6 Maths

with Miss Maths

# Daily maths with Miss Maths

- ▶ My group can join me at 11am or work through this power point at home.
- ▶ Your year 6 teachers have set you work from Oak academy. Have a look at yesterday's lesson.
- ▶ My little tips on angles are to help you understand and memorise key information.
- ▶ Please try to answer questions in full sentences even if that means talking to yourself in an empty room. Explaining your mathematical ideas in clear sentences is so important. 😊



# Angles

Today we will finish our learning from yesterday.

- ▶ Angles in triangles
- ▶ Finding missing angles

# Angles

- ▶ An angle is a measure of a turn
- ▶ It is measured in degrees
- ▶ This is the symbol for degrees: °
- ▶ There are 4 types of angles we need to know in year 6.
  
- ▶ Let's watch the BBC bitesize video on the 4 types of angles

<https://www.bbc.co.uk/bitesize/topics/zb6tyrd/articles/zg68k7h>

- ▶ Play the games too!

# Memory hooks:



- ▶ Acute=less than  $90^\circ$  ...cute baby is very little



- ▶ right-angle =  $90^\circ$

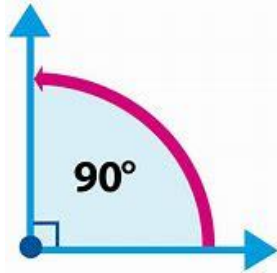

- ▶ Obtuse = greater than  $90^\circ$  but less than  $180^\circ$

I make a word link ...**ob**tuse...**ob**esity..link to being bigger

- ▶ Reflex angle = greater than  $180^\circ$  but less than  $360^\circ$

I make a word link...I think of a super **flex**ible gymnast...biggest angle!



# Angles in a triangle

- ▶ All of the angles in a triangle add up to  $180^\circ$

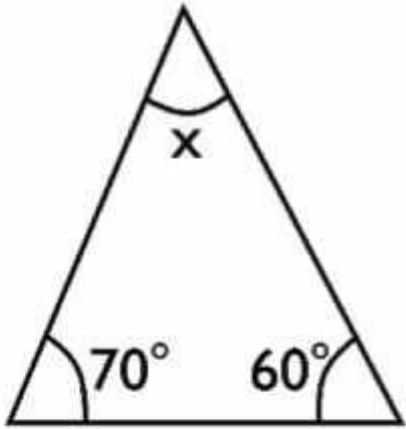

Angles in a triangle add up to  $180^\circ$

180°		
70°	60°	?

- Add together the 2 angles that you do know.  
 $70 + 60 = 130$
- Subtract the 2 angles from  $180^\circ$  to find the missing angle.

$$\begin{array}{r} 180 \\ - 130 \\ \hline \end{array}$$

50 so the missing angles measures  $50^\circ$

Key fact: All of the angles in a triangle add up to  $180^\circ$



The game of darts helps me remember this key fact. What does this dart board have to do with 180?



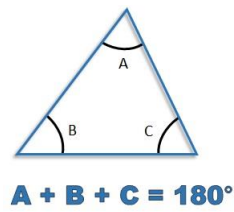

Calculate the missing angles:  
Represent each calculation with a bar model.

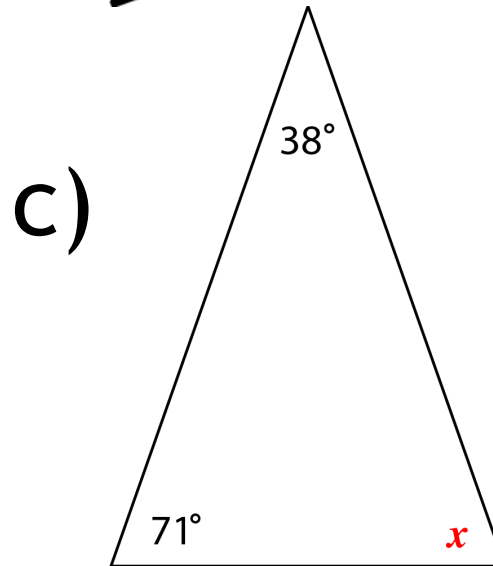
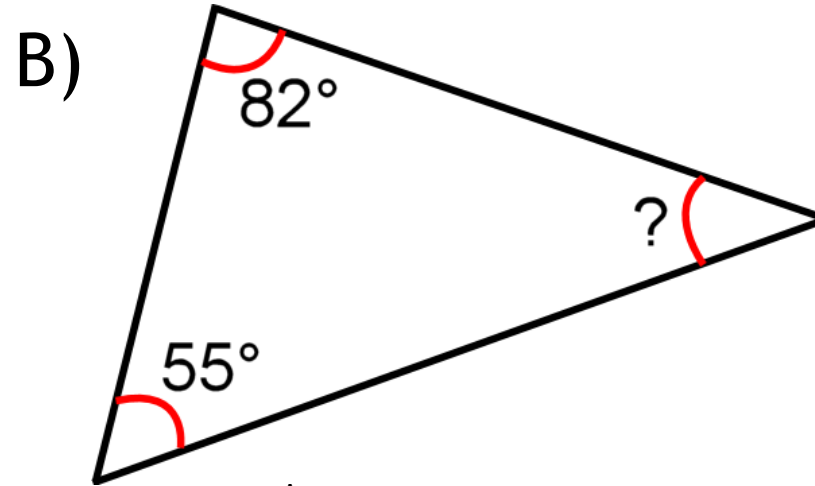
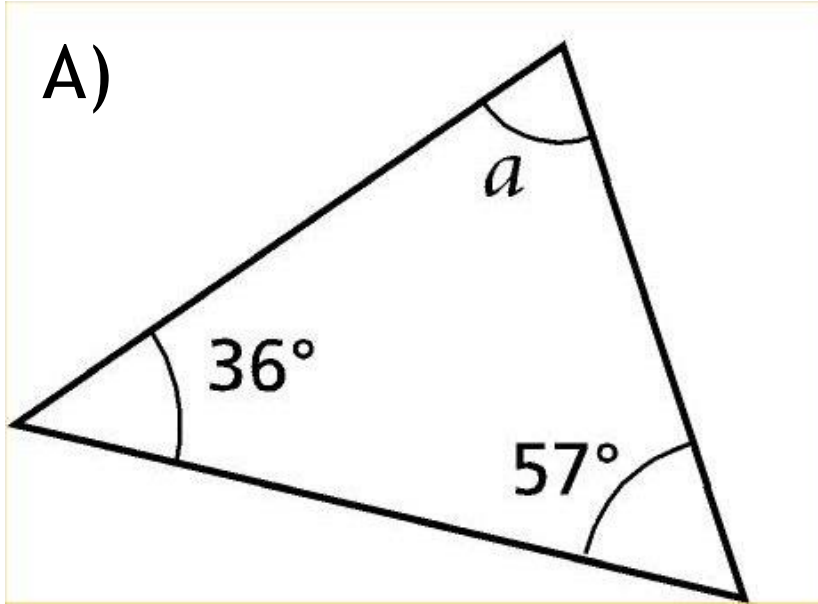

How does 'angles' link to last week's algebra topic?



# Let's take a closer look at triangle C)

C)

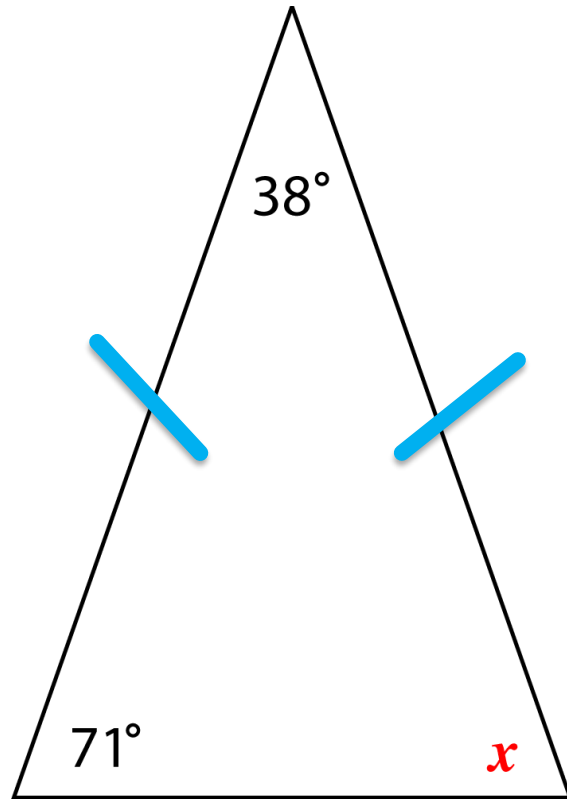

This is a special type of triangle called an Isosceles triangle.

It has 2 equal sides and 2 equal angles.

The 2 blue lines show us that the lines are equal. Look out for this because it means that some of the hard work has already been done!

180°		
71°	71°	38°

# Calculate the missing angles:

isosceles triangle questions 1

find the missing angles in these triangles

(1)

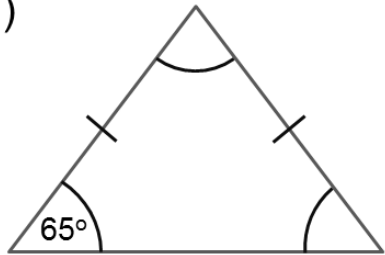

(2)

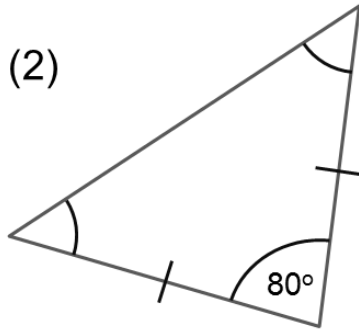

(3)

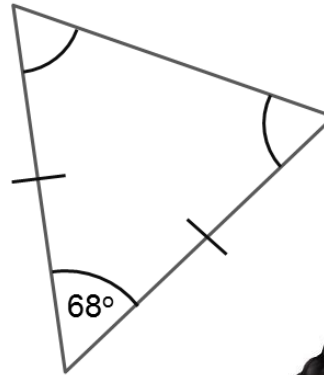

(4)

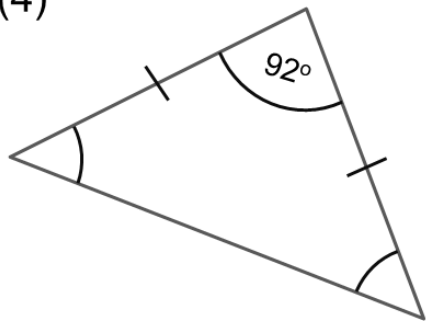

(5)

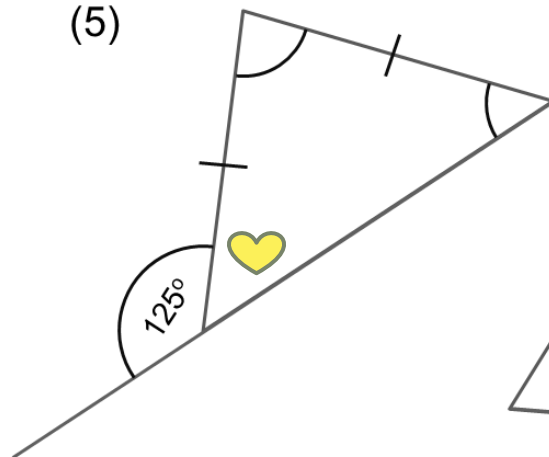

(6)

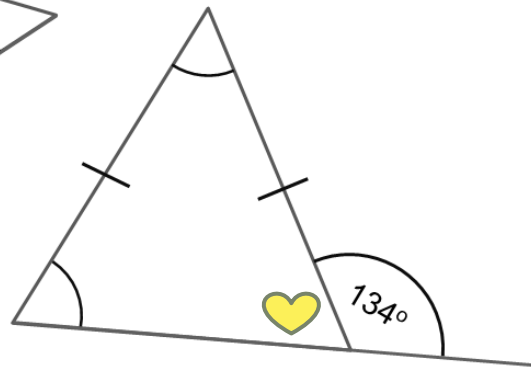

Challenge time!  
Look at question 5.  
We are only given an exterior angle but not an interior angle.  
How will the exterior angle help you figure out the adjacent interior angle?



More key facts we need to know:

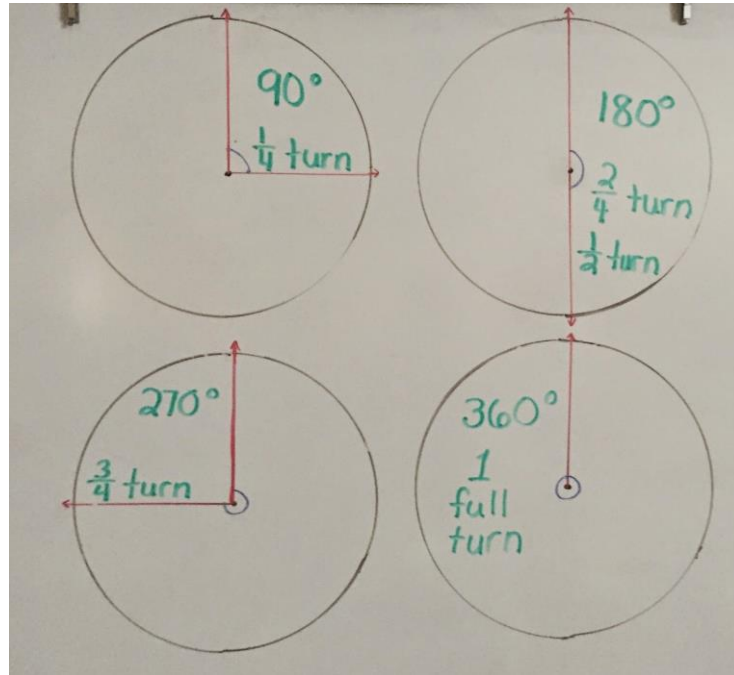

Knowing that a **straight line angle** =  $180^\circ$   
and that a **full turn** =  $360^\circ$  will help you  
with many missing angle questions!

Can you work out each angle?  
What is the name of this type of triangle?

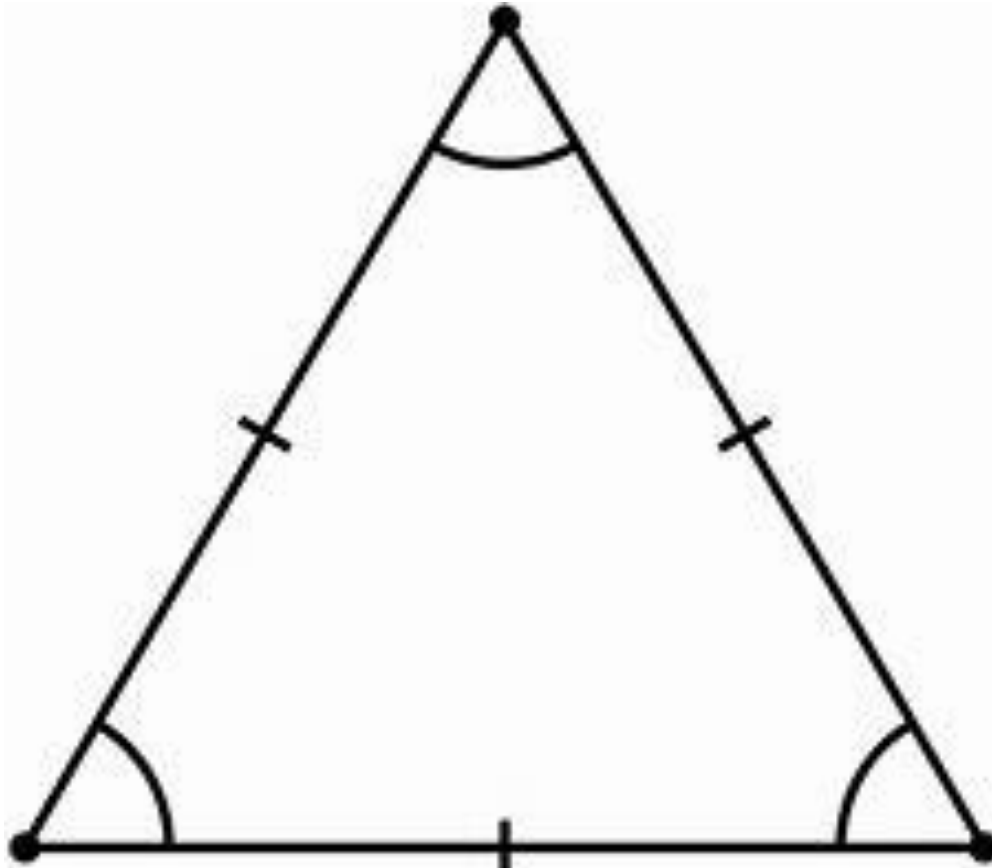

# The 4 main types of triangles

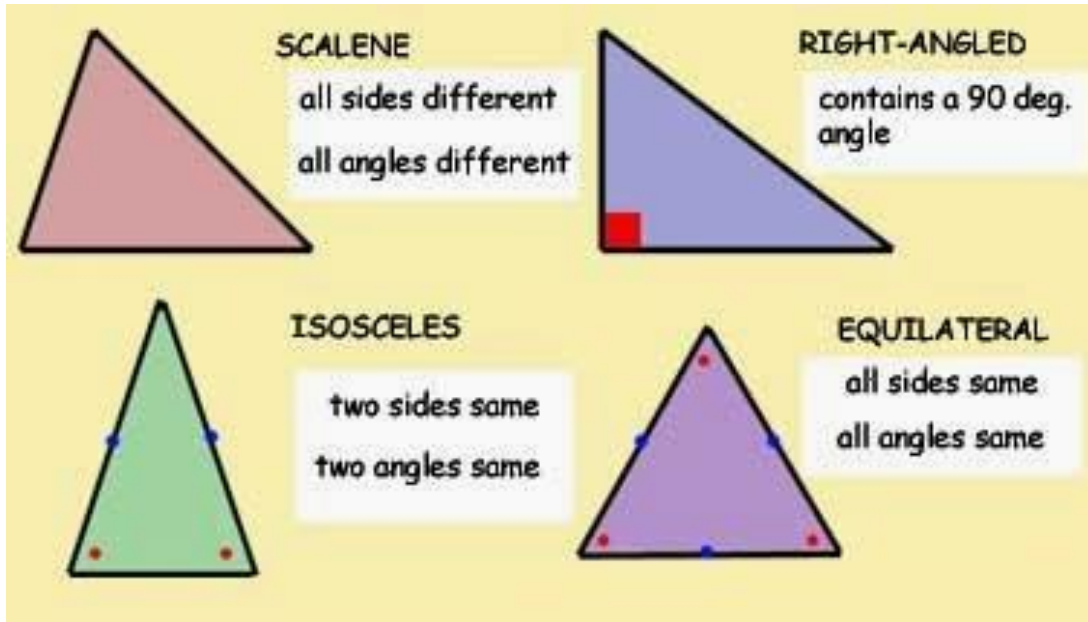

Knowing which type of triangle you have will help you find out the missing angle. Look for clues...be a detective!

# A Mini challenge...



- ▶ Draw a triangle and cut it out.

( You can simply draw a line on the corner of your paper, fold it and then carefully tear off if you can't find any scissors)

- ▶ Mark each angle with a letter A, B and C



- ▶ How can you prove that the angles in a triangle add up to  $180^\circ$  without using an angle measurer?

# A Quick summary of today's lesson

- ▶ We looked at types of angles (acute, right-angle, obtuse, reflex)
- ▶ We looked at types of triangles (right-angled, isosceles, equilateral, scalene)
- ▶ We looked at different types of turns (quarter turn, straight-line,  $\frac{3}{4}$  turn, full turn...)
- ▶ There were important facts we need to remember and things to look out for:
  - little lines tell you that lines are equal
  - identifying a straight-line angle is a useful skill!

Have a look at each question below. How could you solve each one?



■ Calculate the missing angle X. Do not measure!

A

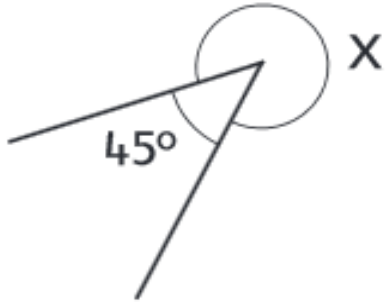

B

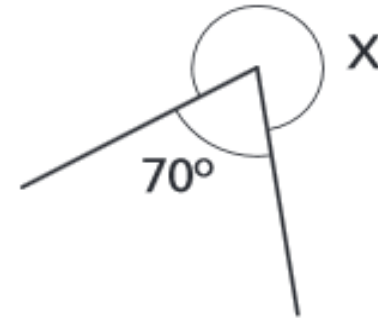

C

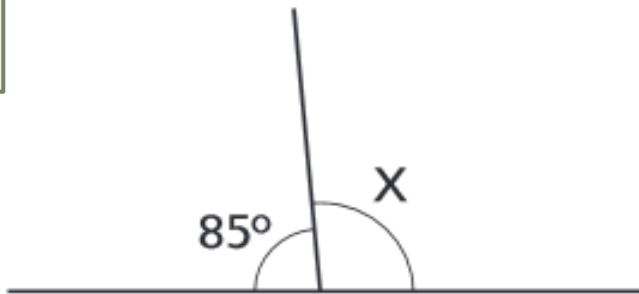

D

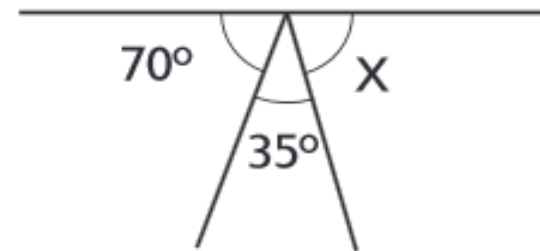

E

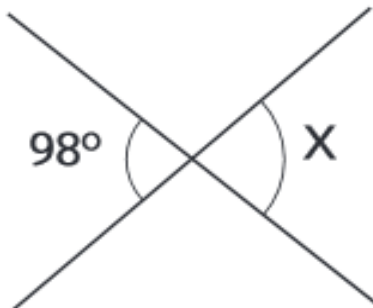

F

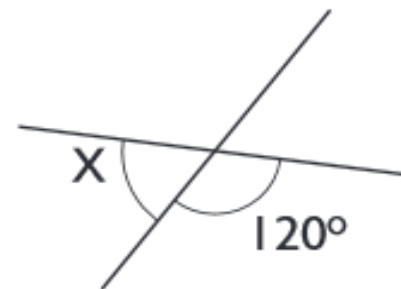



G

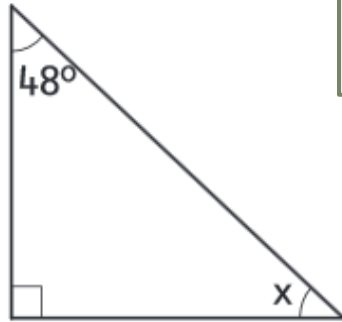

H

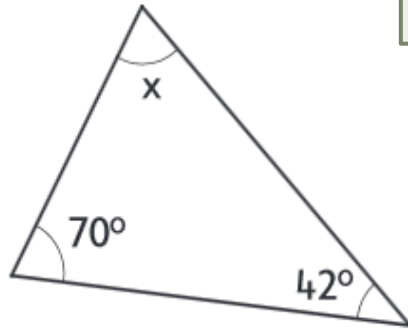

I

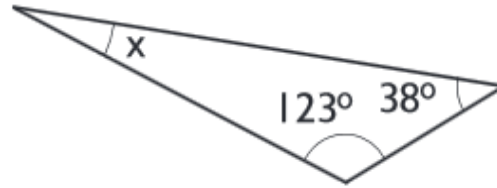

J

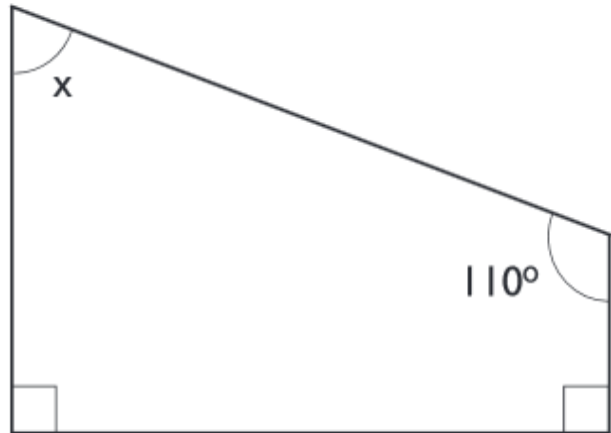

K

